

Phys102 Lecture 20/21

Electromagnetic Induction and Faraday's Law

Key Points

- Induced EMF
- Faraday's Law of Induction; Lenz's Law

References

SFU Ed: 29-1,2,3,4,5,6.

6th Ed: 21-1,2,3,4,5,6,7.

Induced EMF

Almost 200 years ago, Faraday looked for evidence that a magnetic field would induce an electric current with this apparatus:

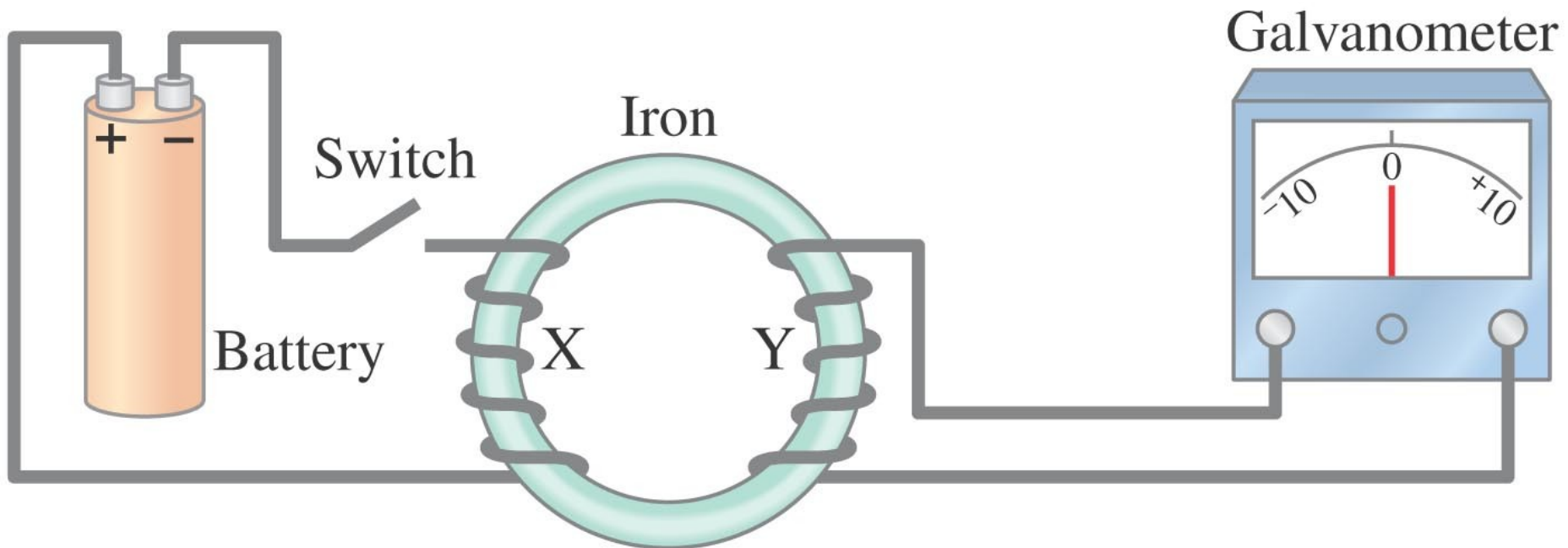

He found no evidence when the current was steady, but did see a current induced when the switch was turned on or off.

Induced EMF

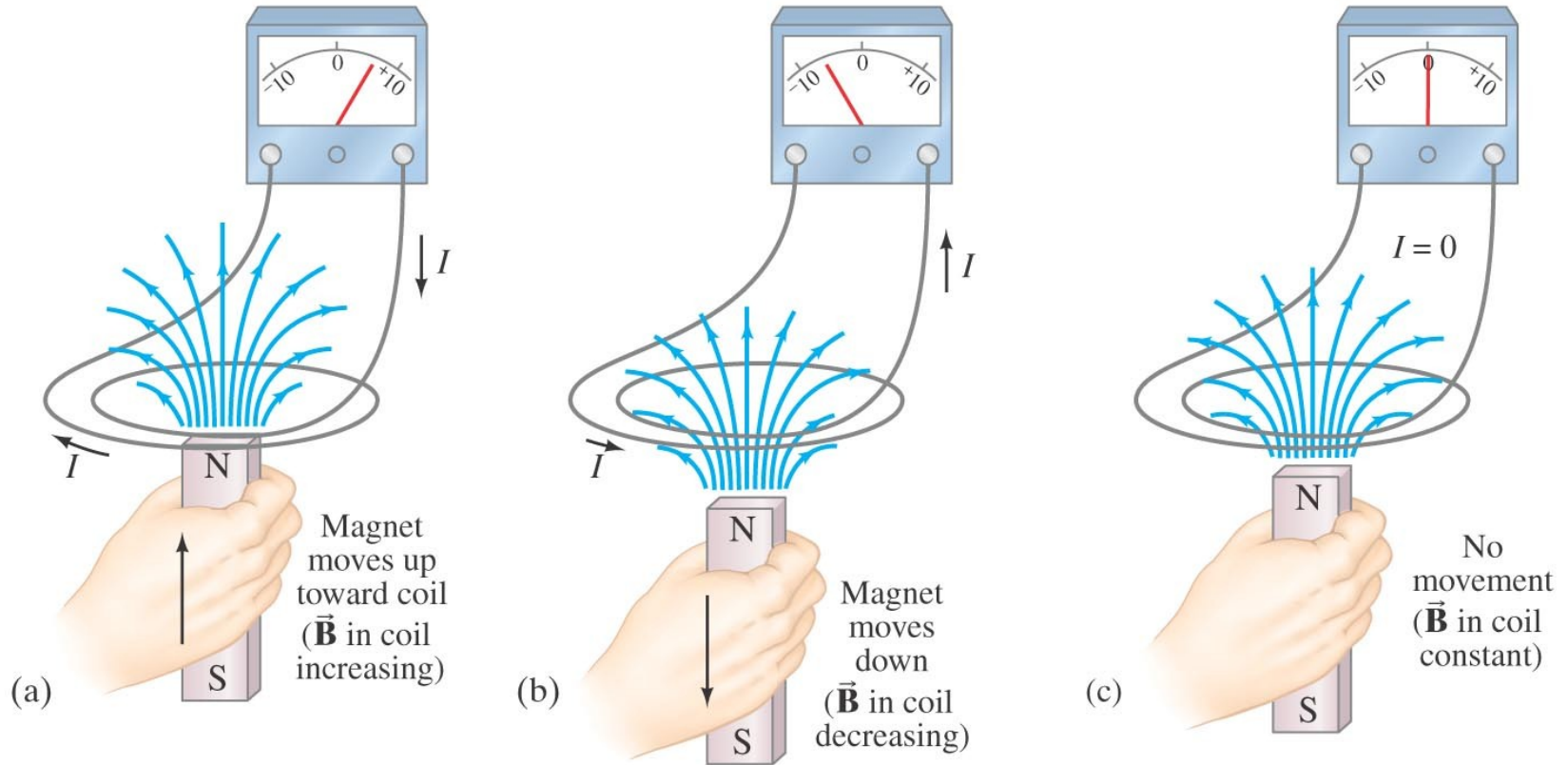

Faraday's Law of Induction

Faraday's law of induction: the emf induced in a circuit is equal to the rate of change of magnetic flux through the circuit:

$$\mathcal{E} = -\frac{d\Phi_B}{dt}.$$

or

$$\mathcal{E} = -N\frac{d\Phi_B}{dt}. \quad [N \text{ loops}]$$

The Magnetic Flux

The magnetic flux is analogous to the electric flux – it is proportional to the total number of magnetic field lines passing through the loop.

$$\Phi_B = \vec{B} \cdot \vec{A} = BA \cos \theta$$

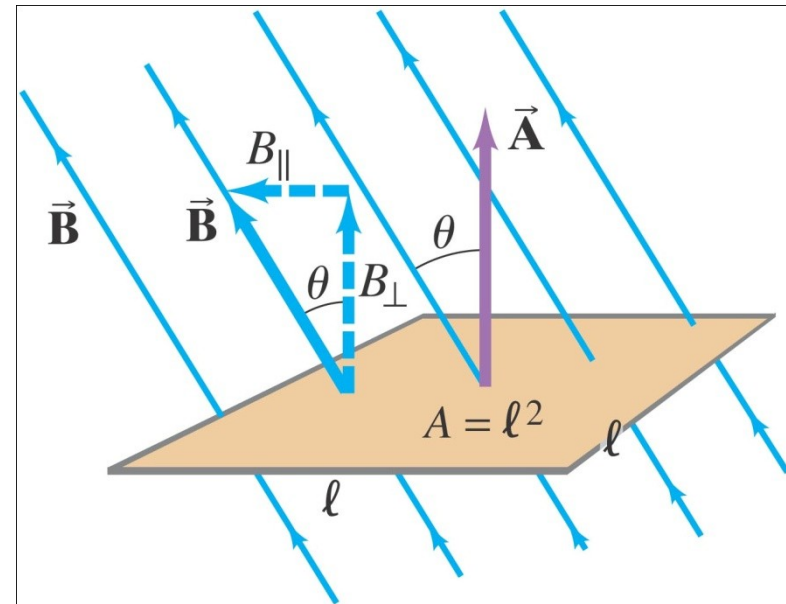
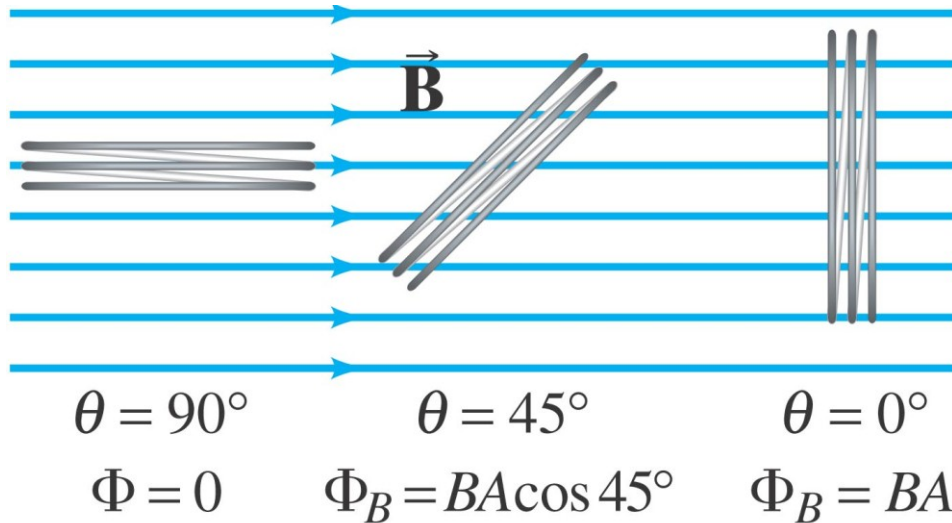

Lenz's Law

The minus sign in Faraday's law gives the direction of the induced emf:

A current produced by an induced emf moves in a direction so that the magnetic field it produces tends to restore the changed field.

or:

An induced emf is always in a direction that opposes the original change in flux that caused it.

$$\mathcal{E} = -N \frac{d\Phi_B}{dt}$$

Example 29-2: A loop of wire in a magnetic field.

A square loop of wire of side $\ell = 5.0$ cm is in a uniform magnetic field $B = 0.16$ T. What is the magnetic flux in the loop (a) when \vec{B} is perpendicular to the face of the loop and (b) when \vec{B} is at an angle of 30° to the area \vec{A} of the loop? (c) What is the magnitude of the average current in the loop if it has a resistance of 0.012Ω and it is rotated from position (b) to position (a) in 0.14 s?

Conceptual Example 29-4: Practice with Lenz's law.

In which direction is the current induced in the circular loop for each situation?

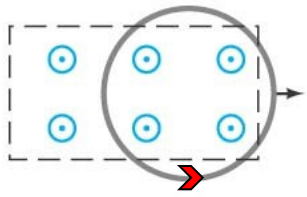

(a)

Pulling a round loop to the right out of a magnetic field which points out of the page

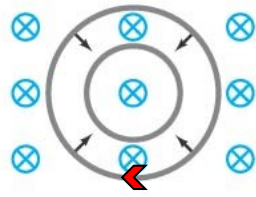

(b)

Shrinking a loop in a magnetic field pointing into the page

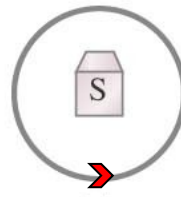

(c)

S magnetic pole moving from below, up toward the loop

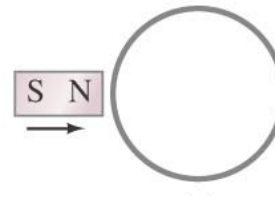

(d)

N magnetic pole moving toward loop in the plane of the page

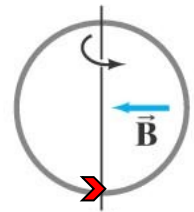

(e)

Rotating the loop by pulling the left side toward us and pushing the right side in; the magnetic field points from right to left



i-clicker 20-1: Moving Wire Loop I

A wire loop is moving through a uniform magnetic field. What is the direction of the induced current?

- A) clockwise**
- B) counterclockwise**
- C) no induced current**

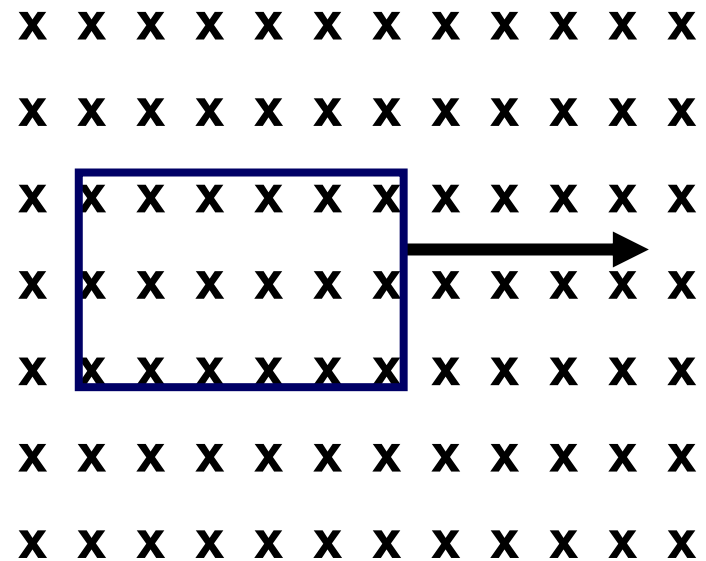



i-clicker 20-2:

What is the direction of the induced current if the B field suddenly increases while the loop is in the region?

- A) clockwise**
- B) counterclockwise**
- C) no induced current**

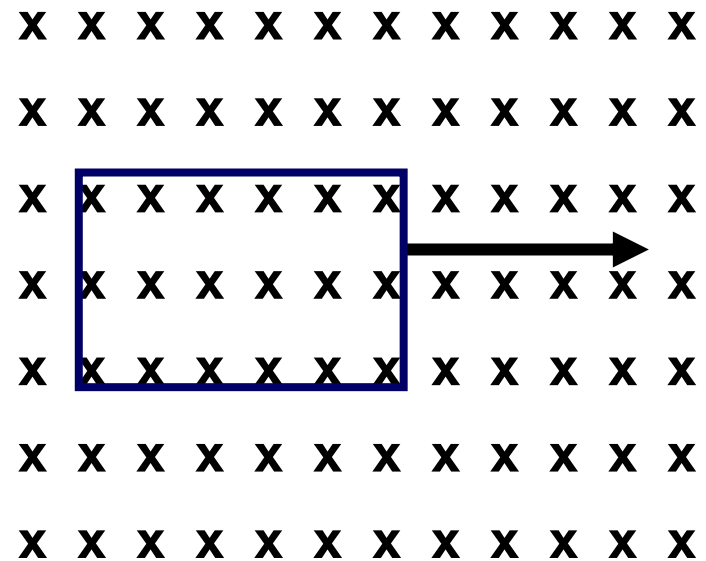



i-clicker 20-3

A wire loop is moving through a uniform magnetic field that suddenly ends. What is the direction of the induced current?

- A) clockwise**
- B) counterclockwise**
- C) no induced current**

x x x x x

x x x x x

x x x x x

x x x x x

x x x x x

x x x x x

x x x x x



i-clicker 20-4: Shrinking Wire Loop



If a coil is shrinking in a magnetic field pointing into the page, in what direction is the induced current?

- A) clockwise
- B) counterclockwise
- C) no induced current

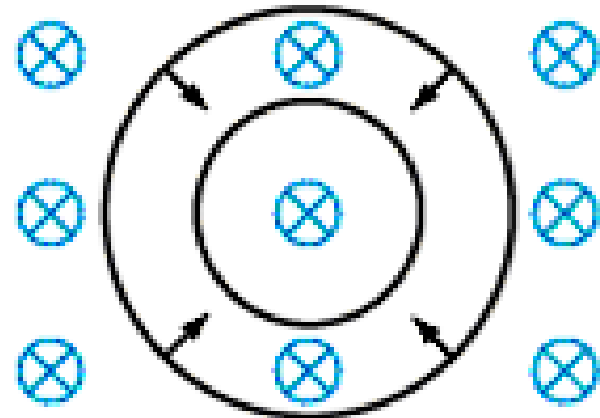

EMF Induced in a Moving Conductor

This is another way to change the magnetic flux:

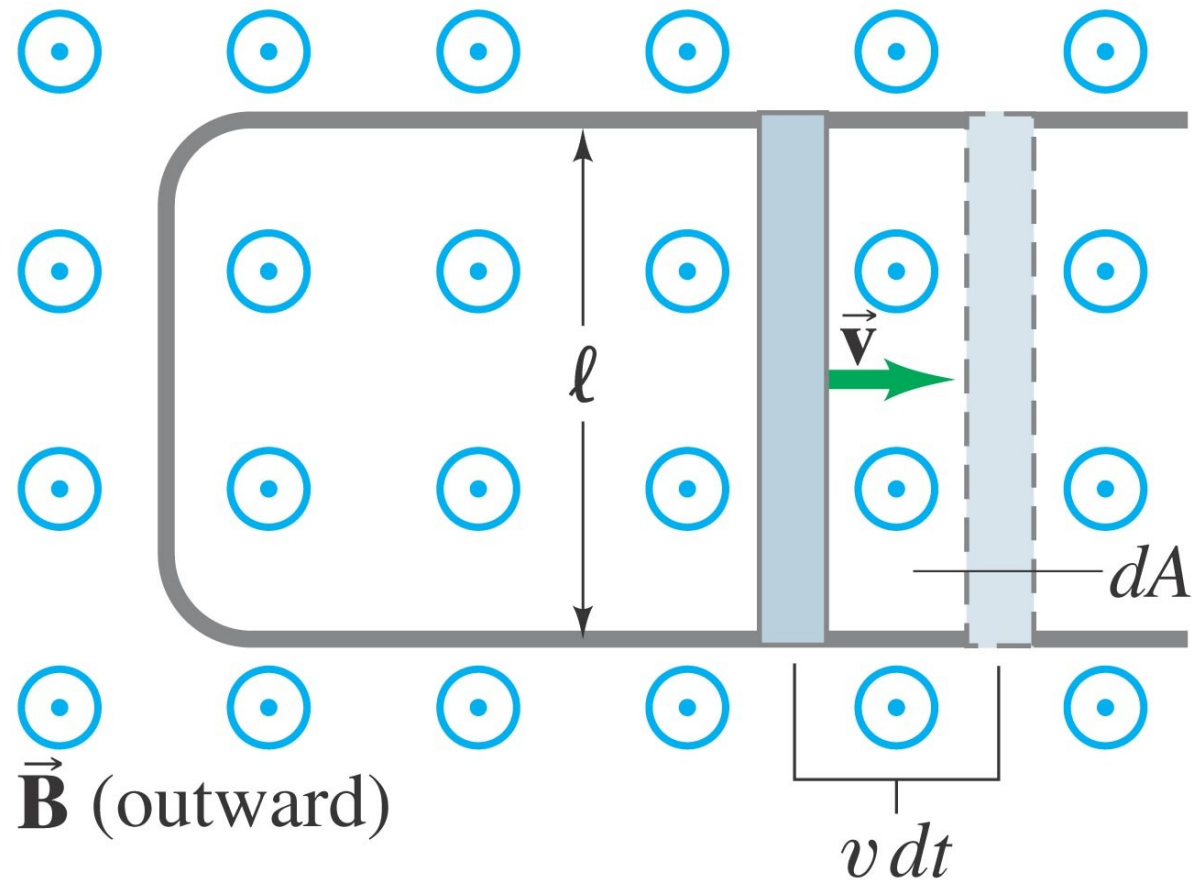

The induced emf has magnitude

$$\mathcal{E} = \frac{d\Phi_B}{dt} = \frac{B dA}{dt} = \frac{B\ell v dt}{dt} = B\ell v.$$

This equation is valid as long as B , ℓ , and v are mutually perpendicular (if not, it is true for their perpendicular components).

Example 29-6: Does a moving airplane develop a large emf?

An airplane travels 1000 km/h in a region where the Earth's magnetic field is about 5×10^{-5} T and is nearly vertical. What is the potential difference induced between the wing tips that are 70 m apart?



Example 29-8: Force on the rod.

To make the rod move to the right at speed v , you need to apply an external force on the rod to the right. (a) Explain and determine the magnitude of the required force. (b) What external power is needed to move the rod? The resistance of the whole circuit is R .

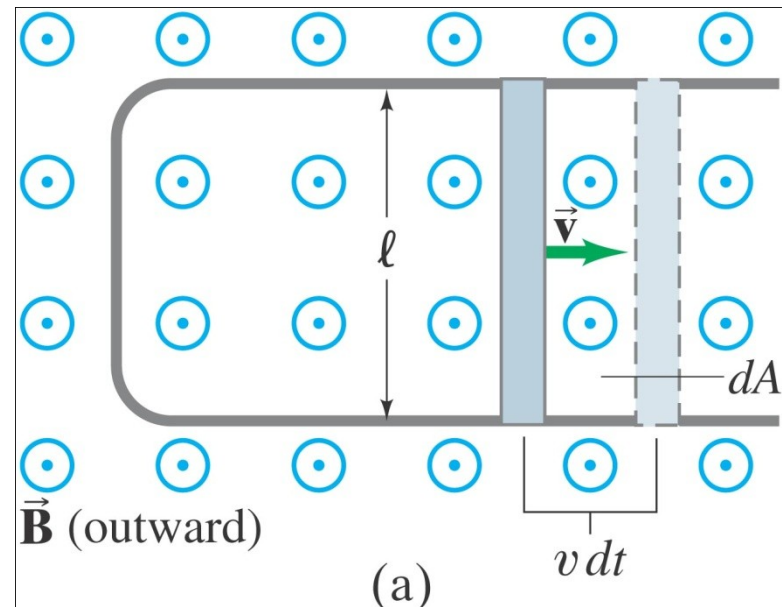

29-4 Electric Generators

A generator is the opposite of a motor – it transforms mechanical energy into electrical energy. This is an ac generator:

The axle is rotated by an external force such as falling water or steam. The brushes are in constant electrical contact with the slip rings.

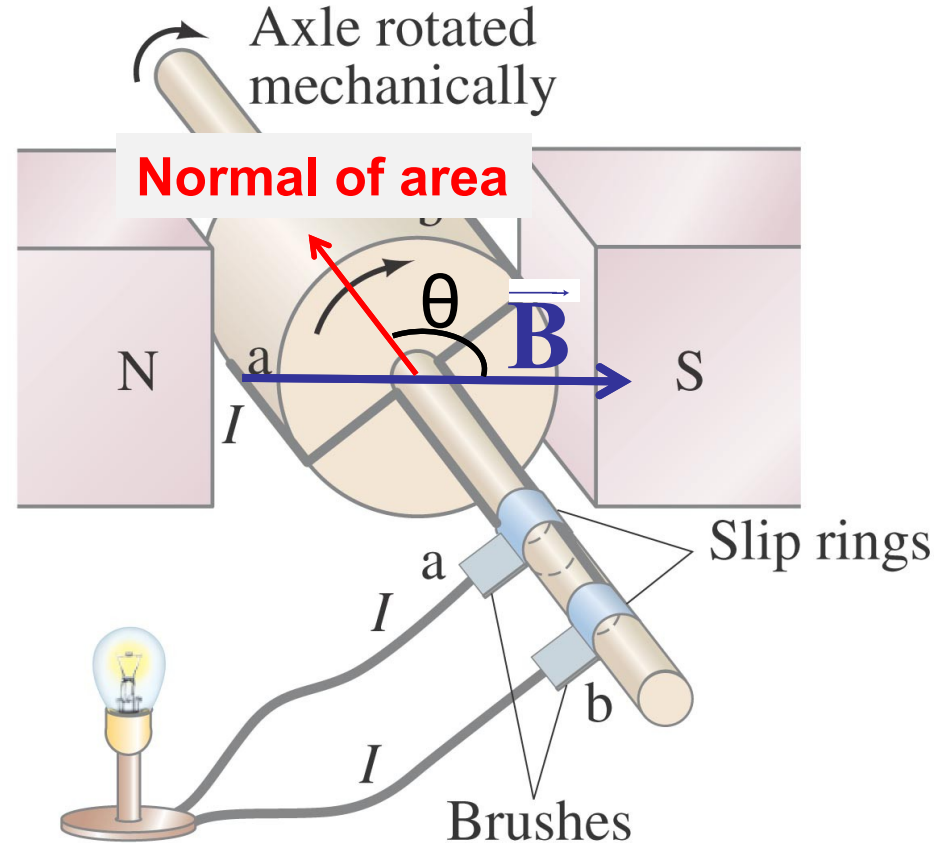

$$\theta = \omega t$$

$$\Phi_B = BA \cos \theta$$

$$= BA \cos(\omega t)$$

If the loop is rotating with constant angular velocity ω , the induced emf is sinusoidal:

$$\mathcal{E} = -BA \frac{d}{dt} (\cos \omega t) = BA\omega \sin \omega t.$$

For a coil of N loops,

$$\begin{aligned} \mathcal{E} &= NBA\omega \sin \omega t \\ &= \mathcal{E}_0 \sin \omega t. \end{aligned}$$

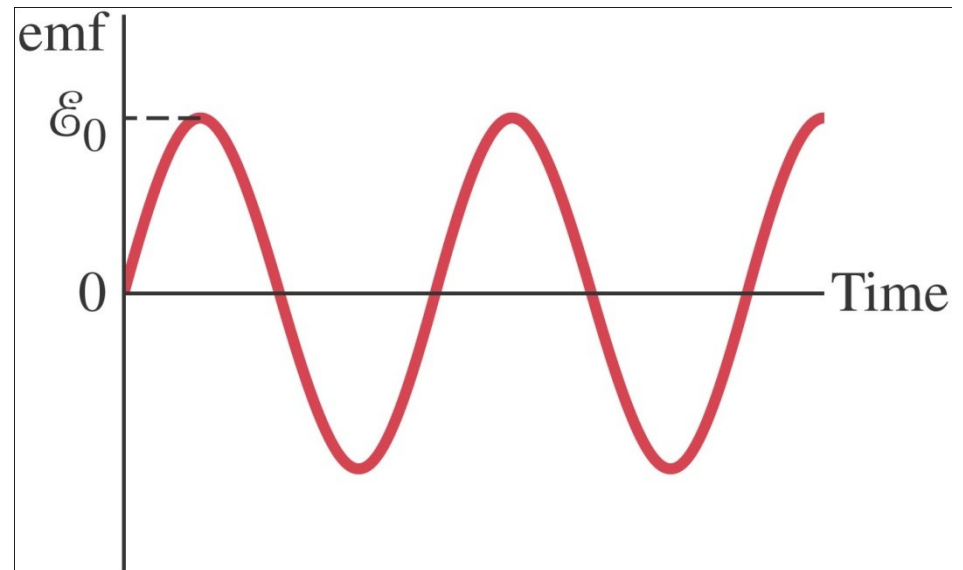

Example 29-9: An ac generator.

The armature of a 60-Hz ac generator rotates in a 0.15-T magnetic field. If the area of the coil is $2.0 \times 10^{-2} \text{ m}^2$, how many loops must the coil contain if the peak output is to be $\mathcal{E}_0 = 170 \text{ V}$?

Eddy Currents

Induced currents can flow in bulk material as well as through wires. These are called eddy currents, and can dramatically slow a conductor moving into or out of a magnetic field.

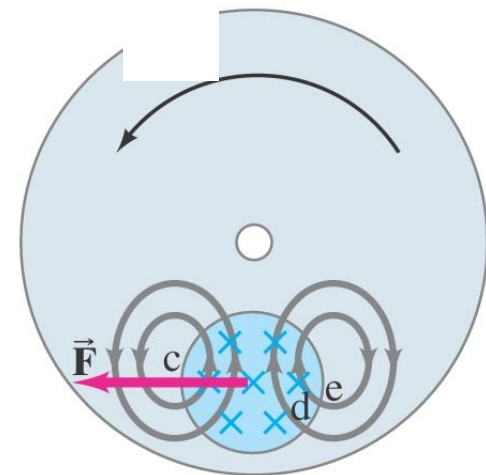
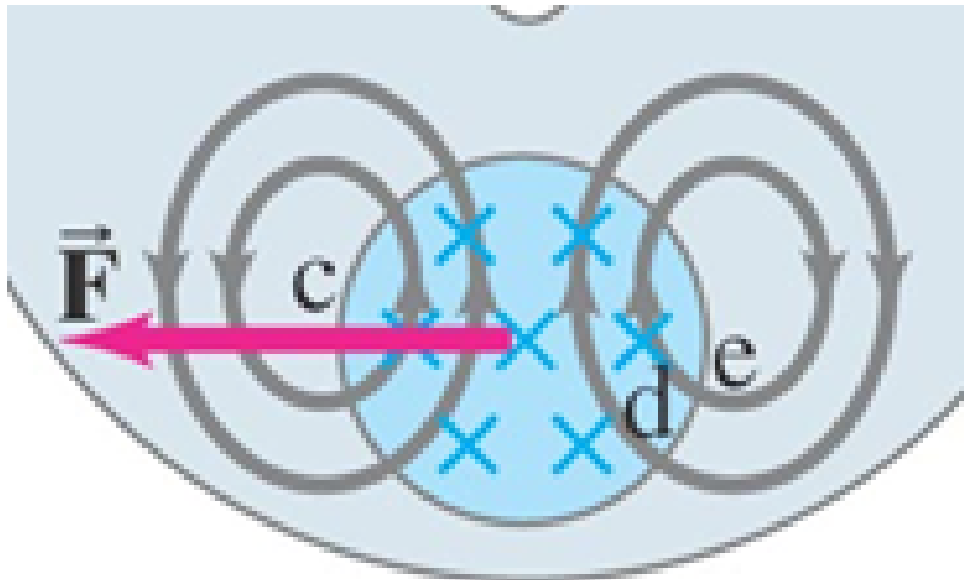
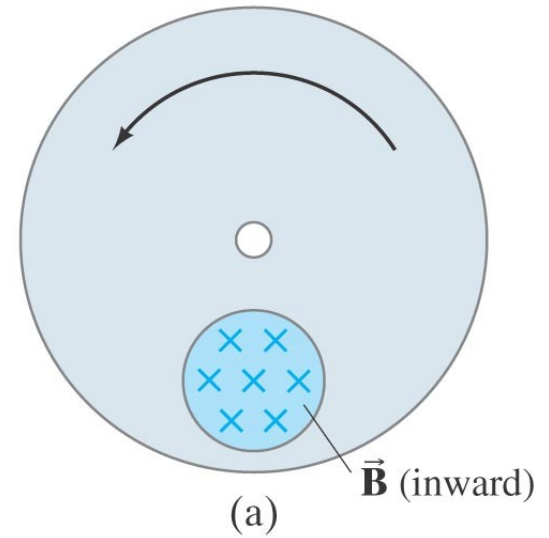

Transformers

This is a step-up transformer – the emf in the secondary coil is larger than the emf in the primary:

$$\frac{V_S}{V_P} = \frac{N_S}{N_P}.$$

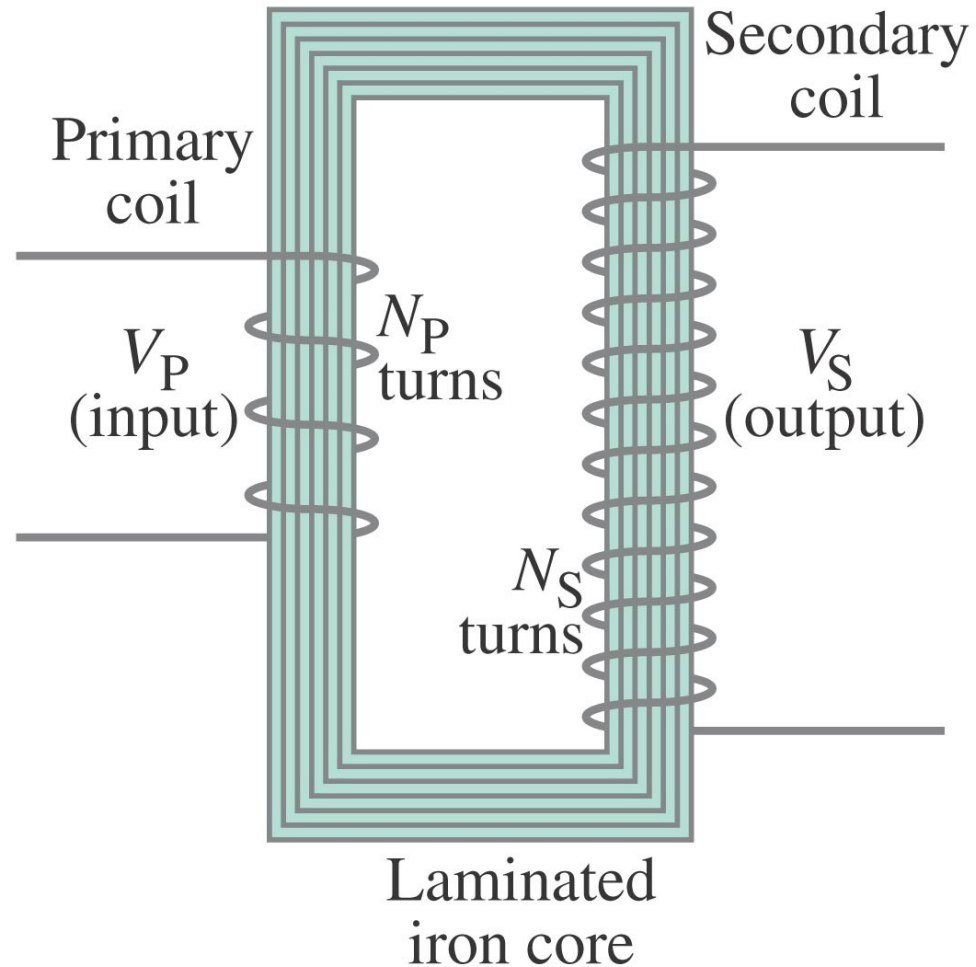



**What is the
voltage across
the lightbulb?**

- A) 30 V
- B) 60 V
- C) 120 V
- D) 240 V
- E) 480 V

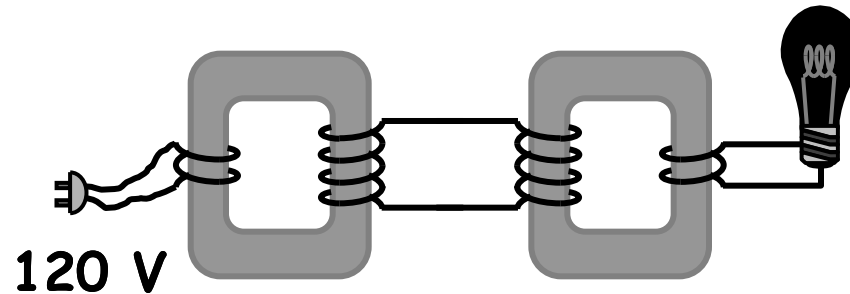

ConceptTest 29.12c Transformers III



A 6 V battery is connected to one side of a transformer. Compared to the voltage drop across coil A, the voltage across coil B is:

- A) greater than 6 V
- B) 6 V
- C) less than 6 V
- D) zero

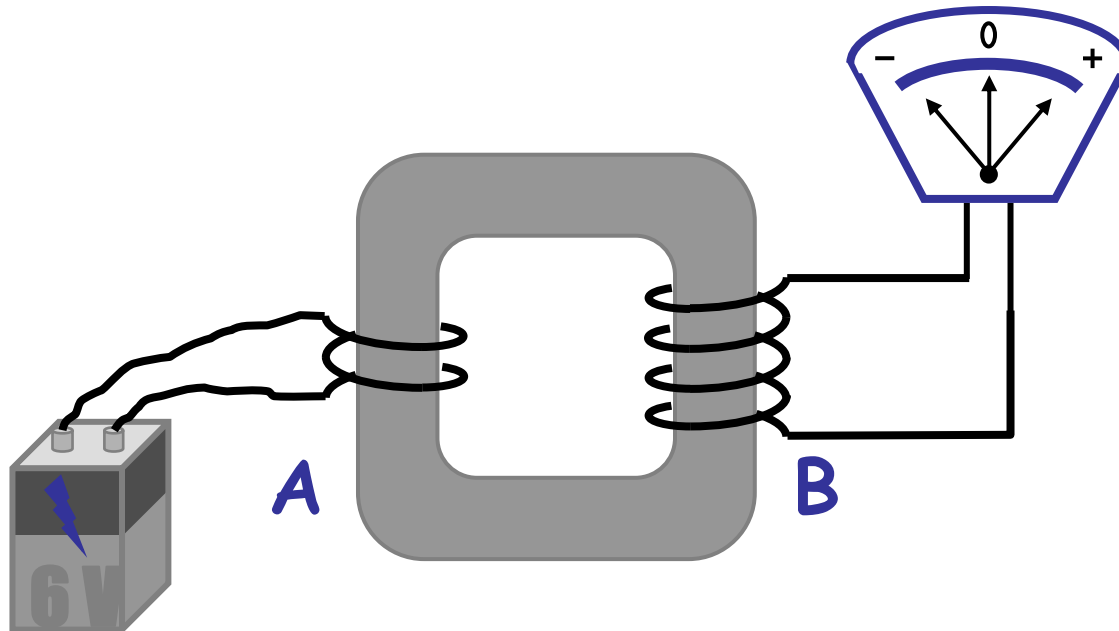

Transmission of Power

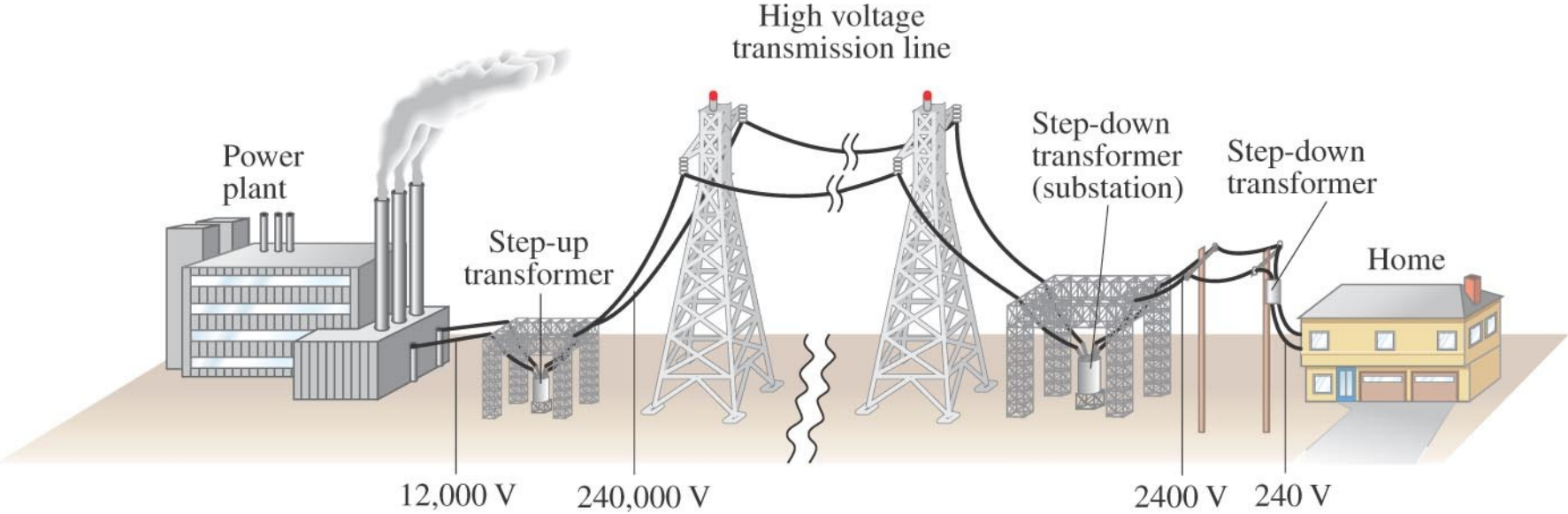

Example 29-13: Transmission lines.

An average of 120 kW of electric power is sent to a small town from a power plant 10 km away. The transmission lines have a total resistance of 0.40 Ω . Calculate the power loss if the power is transmitted at (a) 240 V and (b) 24,000 V.